

Safer Roads and Roadsides!

*Even the Small Things Can Make a
Difference – Let's Tackle One!*

RCA FORUM 30 November 2012



Keeping New Zealanders Moving



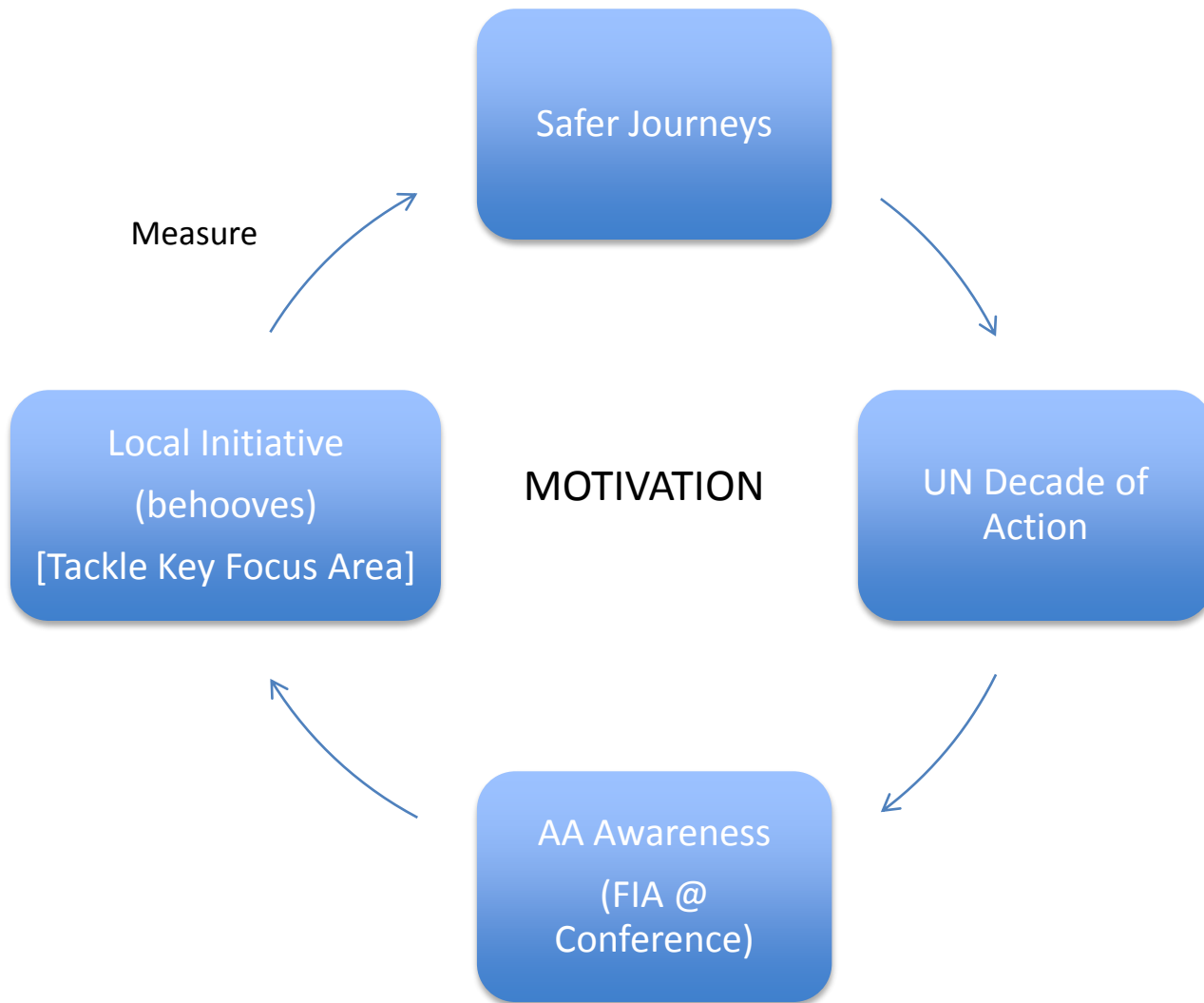

Keeping New Zealanders moving



Safe System

System: a set of **connected** things or parts forming a **complex whole**, in particular a set of things **working together** as parts of.....

Four Key Focus Areas

- *Safe Roads and Roadsides*
- *Safe Speeds*
- *Safe Vehicles*
- *Safe Road Use*



System: An organised set of **interrelated** ideas or principles

System: a group or combination of interrelated, interdependent, or **interacting** elements **forming a collective** entity



Keeping New Zealanders moving



System - Complex Entity

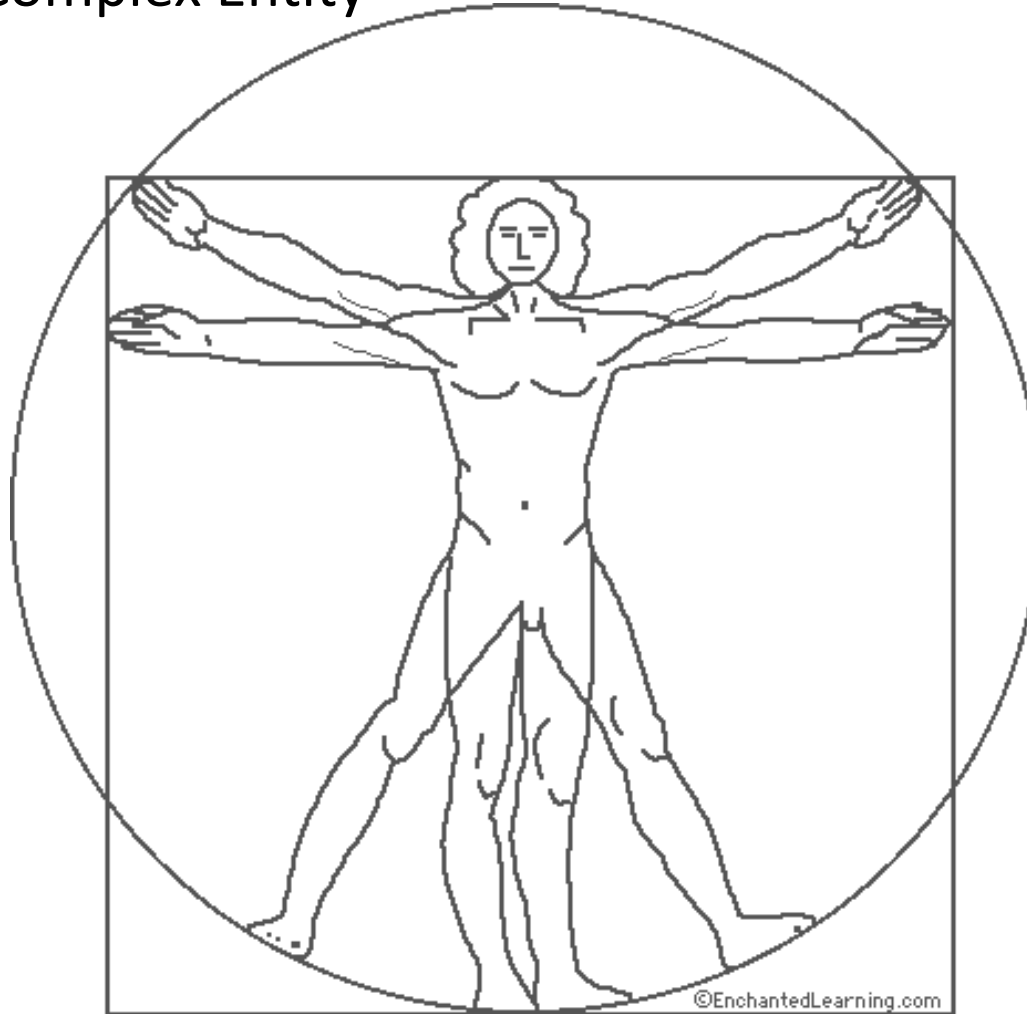

Interacting Elements

- Nervous
- Reproductive
- Vascular
- Digestive
- Lymphatic
- Skeletal
- Muscular
- Respiratory

.....
.....



Keeping New Zealanders moving



Safe System Approach the Four Key Focus Areas

- **Safe Roads and Roadsides**
- Safe Speeds
- Safe Vehicles
- Safe Road Use



Keeping New Zealanders moving



Our Example

Vulnerable Road Users

- Young Inexperienced Drivers
- Push Cyclists
- Motor Cyclists
- **Pedestrians**
 - Elderly
 - Young



Most at Risk



Keeping New Zealanders moving





Keeping New Zealanders moving





Keeping New Zealanders moving



Proven Traffic Engineering Measures to Assist Pedestrians

- Crossing the road in Two Installments
 - Refuges (convert two-way into 2 x one-way)
 - Either painted or physical
- Certainty of Decision Making,
 - Assessment of Danger – Face traffic – Be Seen
- Not a Personal Protection Barrier
 - Safe System Approach



Keeping New Zealanders moving





Keeping New Zealanders moving



Looking Good So Far!

But is it all (LGSF)?



Keeping New Zealanders moving



Local Incident #1

- **Motorcyclist** seriously injured in Palmerston North crash
- *9:31 AM Sunday Mar 11, 2012*
- A motorcyclist has been **seriously injured** in Palmerston North.
- He was involved in an accident at the intersection of State Highway 56 and Carey Street in Longburn last night.
- The 25 year-old hit metal bars on a traffic island and was thrown from his motorbike.
- He was taken to **hospital in a serious** condition.



Keeping New Zealanders moving



Local Incident #1

- Motorcyclist seriously injured in Palmerston North crash
- 9:31 AM Sunday Mar 11, 2012
- A motorcyclist has been seriously injured in Palmerston North.
- He was involved in an accident at the intersection of State Highway 56 and Carey Street in Longburn last night.
- The 25 year-old hit metal bars on a traffic island
- He was taken to hospital in a serious condition.



Keeping New Zealanders moving



Pedestrian Refuge Longburn



Keeping New Zealanders moving



Local Incident #2

Rider badly hurt in crash

Kathryn King | Monday, February 7, 2011 8:06

The aftermath: A young man is believed to be in a critical condition following a **motorcycle** crash yesterday. A young Wanganui man **is lucky to be alive** following a motorcycle crash in Springvale yesterday. Whanganui police Acting Sergeant



Keeping New Zealanders moving



Local Incident #2

Rider badly hurt in crash

Kathryn King | Monday, February 7, 2011 8:06

The aftermath: A young man is believed to be in a critical condition following a motorcycle crash yesterday. A young Whanganui man is lucky to be alive following a motorcycle crash in Springvale yesterday. Whanganui police Acting Sergeant



MCpedestrian island
...run into its safety rail....



Keeping New Zealanders moving



Pedestrian Refuge London Street



Keeping New Zealanders moving





Keeping New Zealanders moving





Keeping New Zealanders moving



Common Theme

- The set of things, or elements of the Total System not quite working together ...

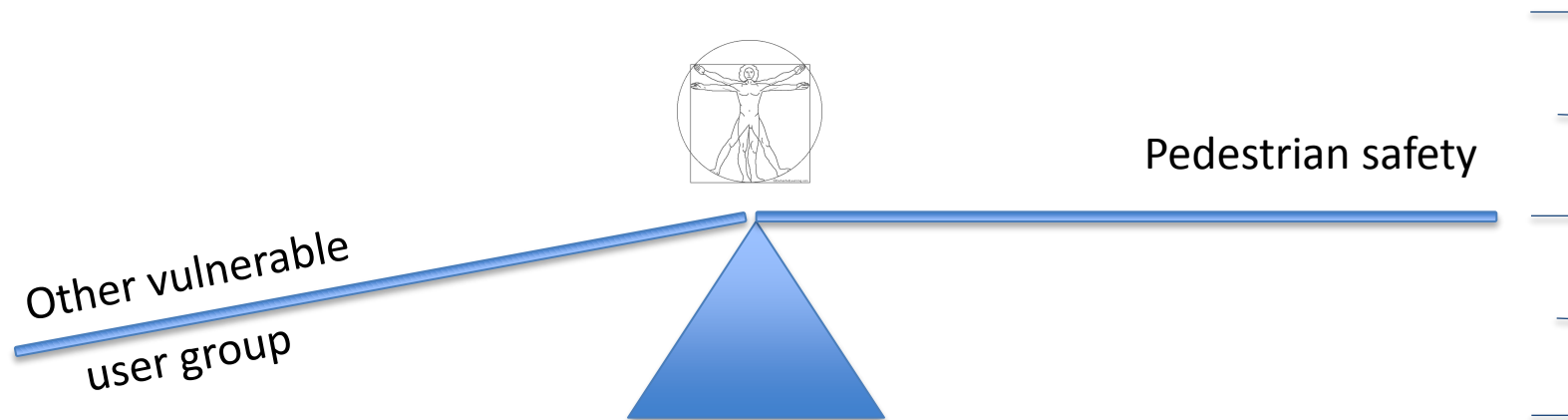

Keeping New Zealanders moving



Bad? - How it Fix It

- Widespread according to literature (18%-42%)
- Clear zone of at least two, and preferably 3.0m from the kerb edge
 - Not always possible
 - Define roadside (L&R)
- Remove unnecessary road side hazards within the design stages of a scheme. (WWY?)
- New potential hazards are frangible



Keeping New Zealanders moving



(HOT DIP GALVANISED TO AS1214)

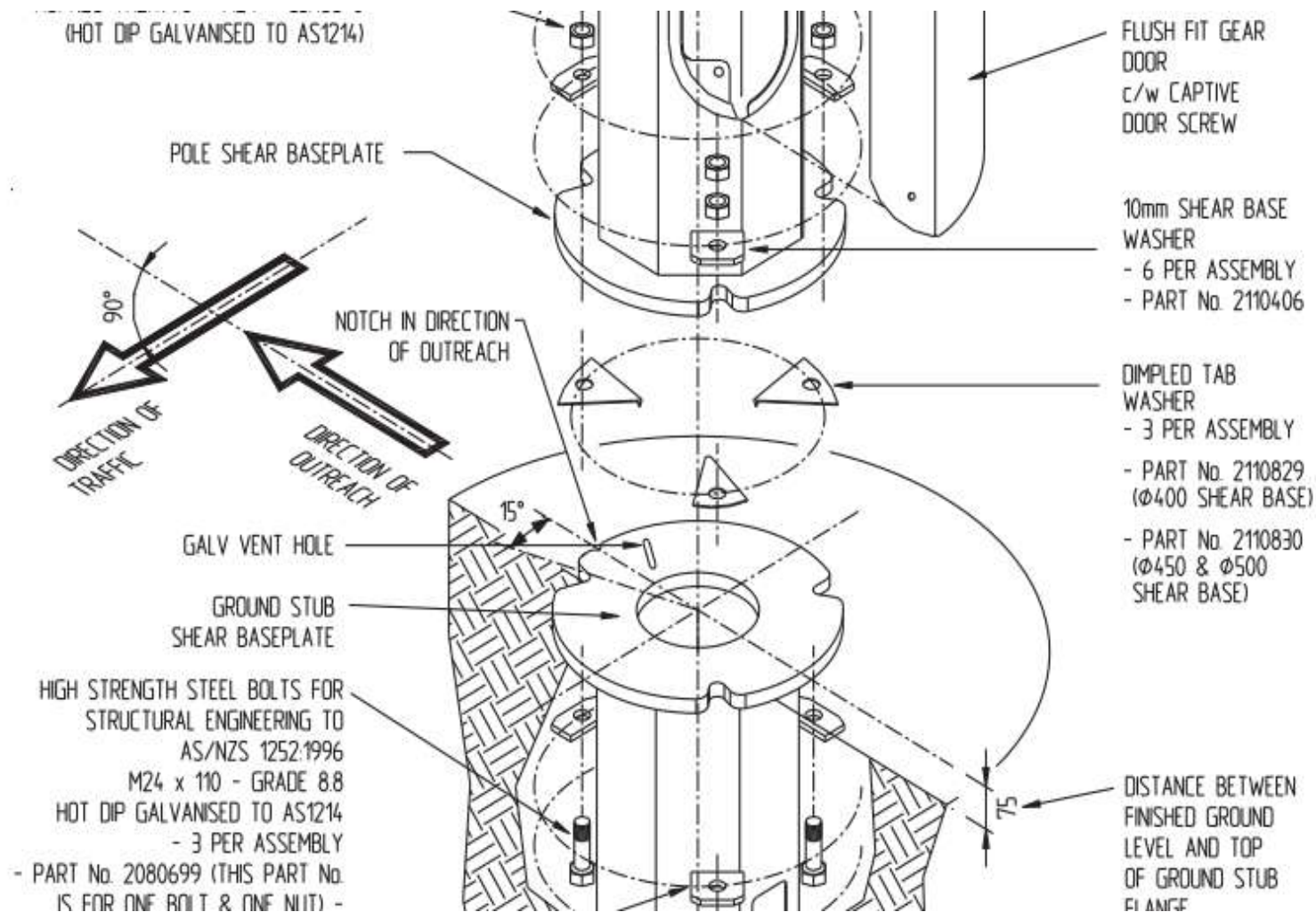

Keeping New Zealanders moving



Completely Frangible



Keeping New Zealanders moving





Keeping New Zealanders moving



Influencers



- Planners
- Engineers
- Policy Makers
- Enforcement Officers
- Vehicle Manufacturers
- Importers
- Educators
- Drivers



System
Designers



Keeping New Zealanders moving



Forward Gear

- Simple initiatives are part of whole system
- Standards, literature and guidelines galore
- Careful thought in context
- Experienced practitioners, skilled teams
- Checklists, reviewing
- Best Practice, training, integrate
- Measure yourself against Safer Journeys Vision



Keeping New Zealanders moving



The End



Keeping New Zealanders moving

